

The Trepko PMG 10 Series machine is a semi-automatic filling machine designed for the bulk filling of boxes with butter type products.

Constructed from food grade stainless steel the machine is equipped with a product compensator directly connected to the filler which ensures a constant and even supply of product between the 3rd party process equipment and the Trepko filler. The PMG-10 machine continually monitors the flow of product from the compensator and can adjust the speed and give feedback to the Trepko filler accordingly. This feedback and adjustment is also used during the CIP process to control the flow of the cleaning agent.

The machines filling process is as follows:

1. The box is pre-folded and then manually placed on the table of the machine.
2. The box is lined with a protective foil bag.
3. The table on which the box is located is automatically moved up under the filling nozzle. The opening of the foil bag is then manually placed around the filling nozzle.
4. The product is then filled. During the filling process the table on which the box is sat moves down until the required level of product is obtained.
5. The filled box is then moved manually from the filling position & on to the outfeed roller conveyor with optional check-weigher. In this position the check-weigher weights the box and provides feedback to the dosing unit to adjust the fill weight if necessary. After achieving the correct weight the box is manually closed.

As an alternative it is possible to equip the machine with a double scroll chute arrangement where the scrolls forced the product to the filling head. In this version the carton is filled in the horizontal position, i.e. the carton opening faces the filling head. Once the filling is completed the carton is moved pneumatically through 90°. This system is not integrated with a weighing cell so extra filling must be done manually following automatic filling process.



PMG 10 series
semi-automatic butter bulk
packaging machine

Trepko

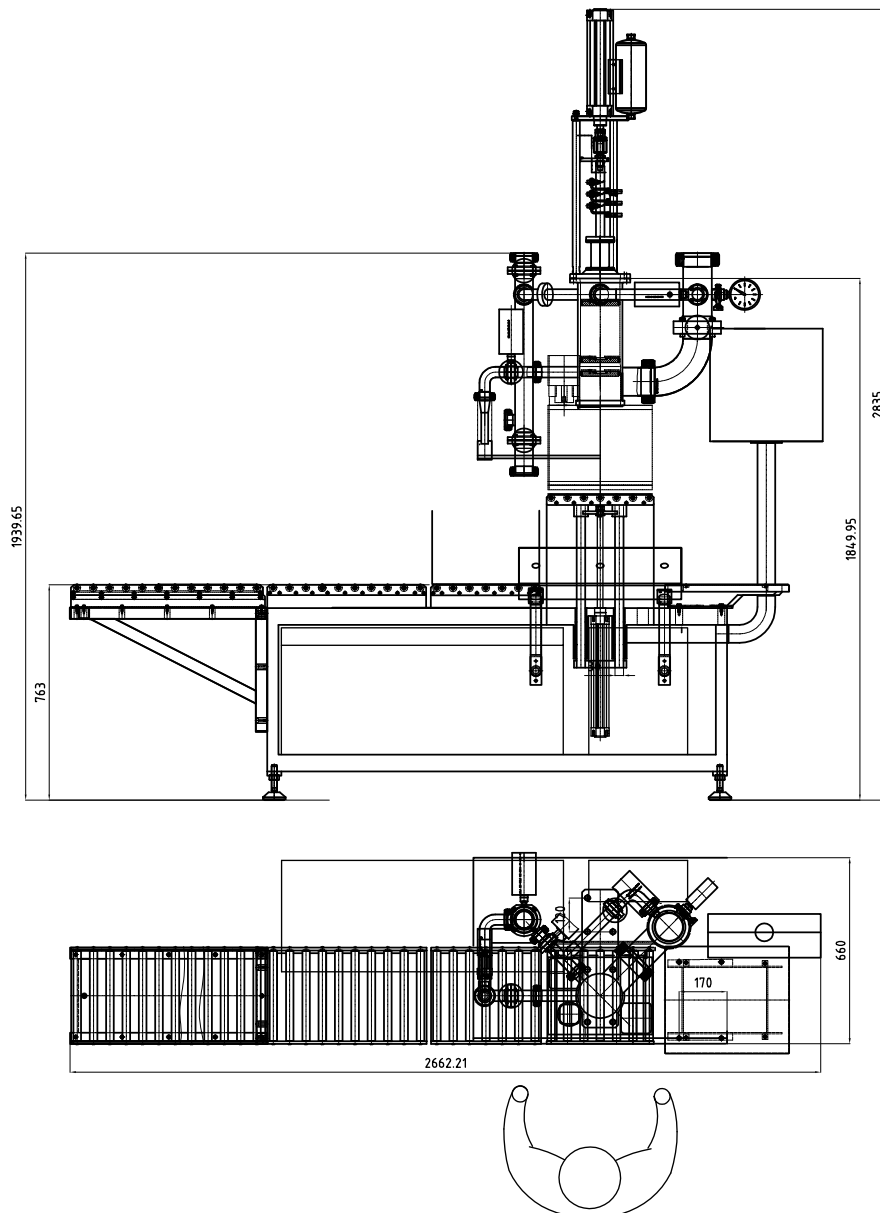

Technical specifications

Output speed:	1,500 kg/hour
Product:	Butter
Dosing and product feed:	Compensator/ Double scroll chute
Maximum box dimensions:	400 x 300 x 300 mm
Power supply:	1x230V + N + PE, 50 Hz
Power consumption:	0,5 kVA
Air consumption:	5 l/min
Manual carton placement and closing	
Integrated weighing cell (optional)	